

# Radio Description

## Street Radio 4402

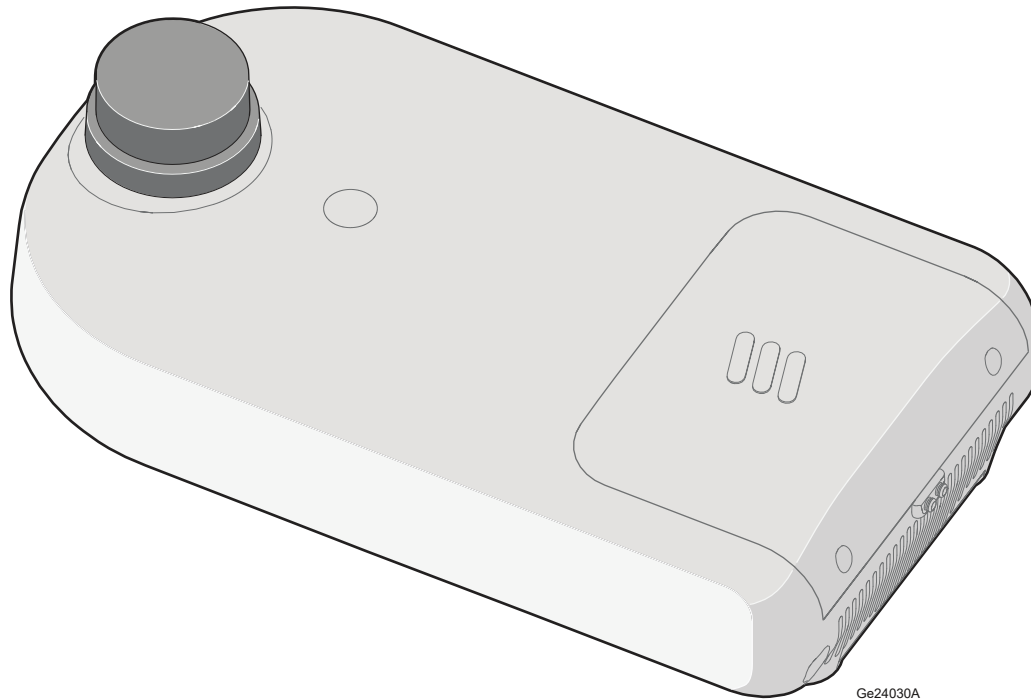

Ge24030A

## Contents

### Introduction

Warranty Seal

### Product Overview

Main Features

Optional Equipment

### Technical Data

Radio Capabilities

Output Power

Physical Characteristics

Antenna

Installation Recommendations

Space Requirements

Acoustic Noise

Environmental Characteristics

Power Characteristics

System Characteristics

### Hardware Architecture

Support 6523

Radio 4402

Antenna

### Connection Interfaces

Radio 4402

**Standards and Regulations**

Regulatory Approval

Other Standards and Regulations

---

# 1 Introduction

## 1.1 Warranty Seal

The product is equipped with a warranty seal sticker.

**Note:** Seals that have been implemented by Ericsson must not be broken or removed, as it otherwise voids warranty.

## 2 Product Overview

The radio expands coverage and performance in denser urban areas, where the use of small handheld devices demand high capacity on the operator networks. It can be mounted on top of luminaires in cities and in demanding radio environments.

The radio is part of a modular radio building concept that is easy to expand. The small size of the radio together with the mounting solution reduces the site volume. The low weight improves the handling of the radio.

An optic cable connects the radio to the main unit, or to an expanded Radio System.

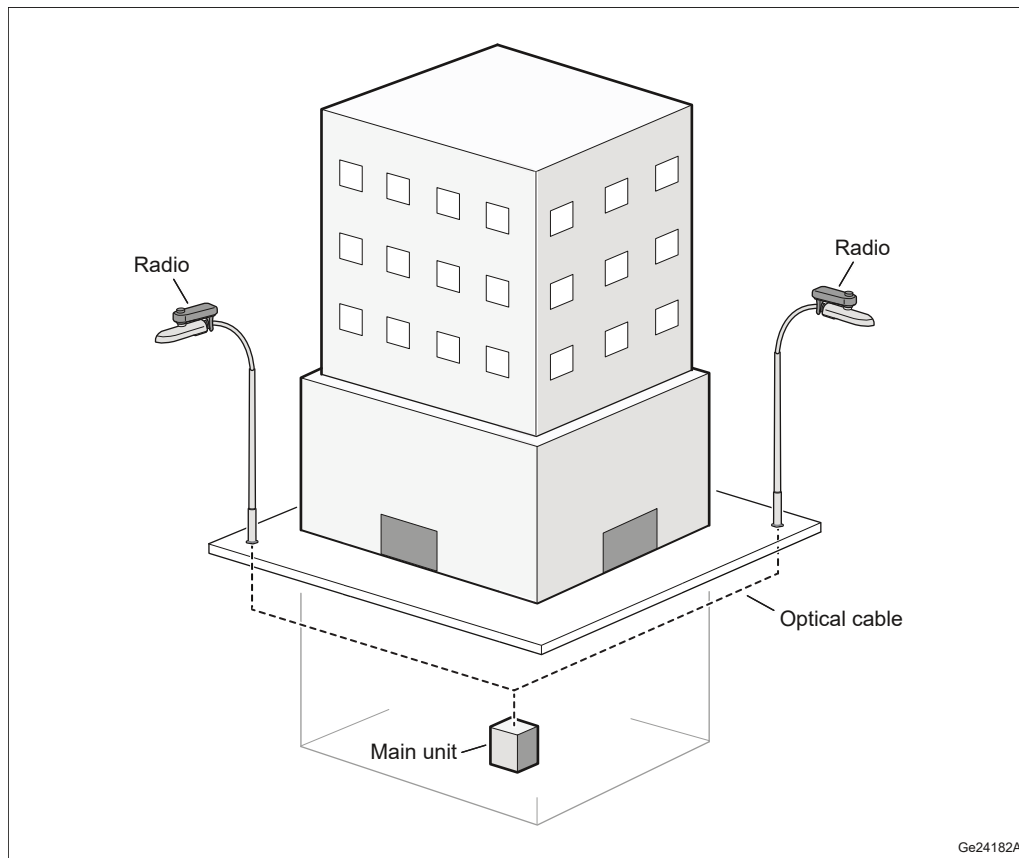

Figure 1 Radio Installations

### 2.1 Main Features

The following are the main features of the radio:

- NR FDD, LTE FDD
- Duplex transmitter/receiver (4TX/4RX) branches with 5 W per branch
- Up to 10.1 Gbps CPRI (optical)
- Complies with 3GPP base station classes Medium Range

For a list of relevant standards, see [Radio Standards Compliance](#).

### 2.2 Optional Equipment

There is no optional equipment for use with Street Radio 4402.

## 3 Technical Data

### 3.1 Radio Capabilities

For supported number of carriers, carrier bandwidth, operating bandwidth, IBW, frequency range, detailed RAT support, see Supported Radio Capabilities.

### 3.2 Output Power

For maximum nominal output power, see Supported Radio Capabilities.

Minimum configured output power where performance is guaranteed is 0.25 W.

For detailed information on licenses and HWACs, see the following:

- LTE, NR: Hardware-Related Capabilities in the Radio Node libraries

For information on maximum output power per carrier type, see Radio Node Configurations.

### 3.3 Physical Characteristics

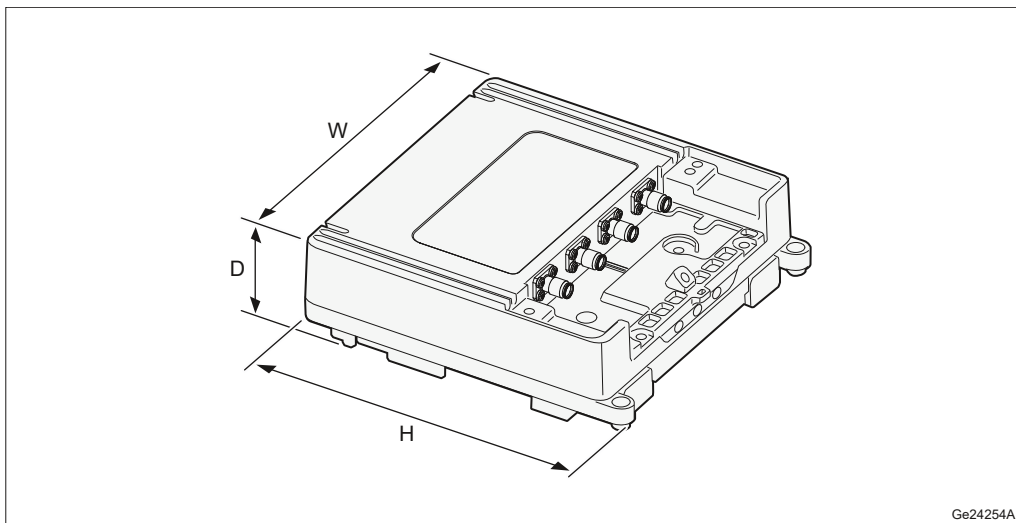

Figure 2 Radio 4402 Dimensions

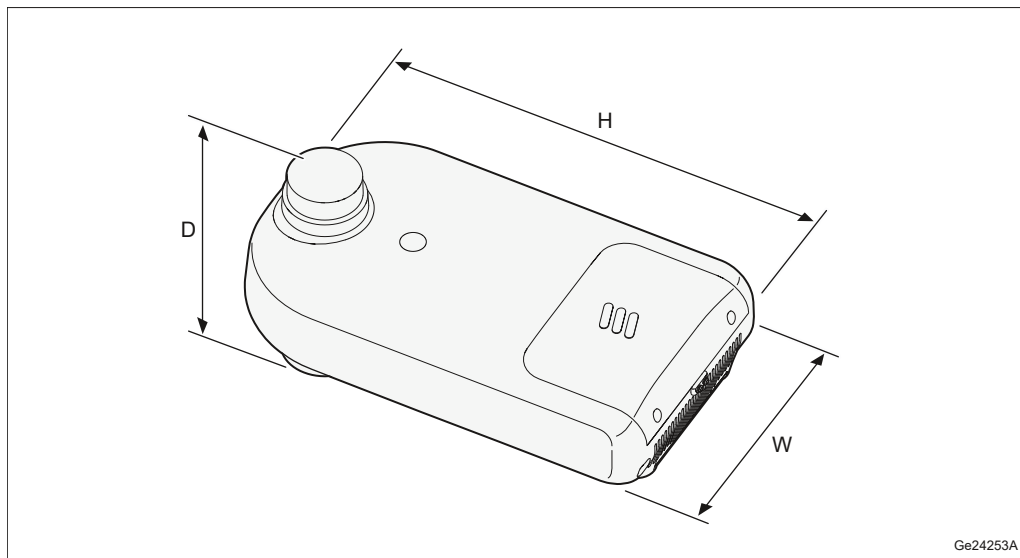

Figure 3 Support 6523 Dimensions

Table 1 Street Radio 4402 Dimensions

| Product                              | Height, H (mm) | Width, W (mm) | Depth, D (mm)      |
|--------------------------------------|----------------|---------------|--------------------|
| Radio 4402 B2/B25<br>Radio 4402 B66A | 214            | 200           | 68                 |
| Support 6523                         | 414            | 239           | 270 <sup>(1)</sup> |

(1) With clamp

Table 2 Street Radio 4402 Weight

| Product                              | Unit Weight (kg)           |
|--------------------------------------|----------------------------|
| Radio 4402 B2/B25<br>Radio 4402 B66A | 3.85                       |
| Support 6523                         | 1.3<br>1.95 <sup>(2)</sup> |

(2) With clamp

Table 3 Street Radio 4402 Color

| Part              | Color Code       |
|-------------------|------------------|
| Radio 4402 Body   | NCS S 1002-B     |
| Support 6523 Body | PMS Cool Gray 4C |

### 3.4 Antenna

Table 4 Antenna Data

| Antenna                                  | Band         | Frequency     | Maximum Gain                     |
|--|--------------|---------------|----------------------------------|
| Integrated omnidirectional antennas 6523 | 2/25 and 66A | 1710–2180 MHz | B2/B25: ≤5.5 dBi<br>B66A: ≤4 dBi |

### 3.5 Installation Recommendations

To ensure reliable operation and maximum performance, an appropriate installation location must be chosen.

If possible, do not install the unit on a luminaire that is directed toward elements that can disturb the radio signals.

### 3.5.1 Installation Locations to Avoid

Although Ericsson declares this product designed for outdoor environments, avoid installing the unit in a potential microclimate location. Typical examples of microclimate locations are sites where the product is not only exposed to the surrounding temperature, but additional temperature as heat from dark-colored planes, for example, reflections from the street asphalt or walls. The additional temperature can generate heat traps with temperatures up to 10°C higher than expected.

Avoid installing equipment in the following locations:

- Near the exhaust of building ventilation systems
- Near the exhaust of chimneys
- Opposite large surfaces made of glass or new concrete

If the unit is to be located in an environment subjected to lightning strike, an external Surge Protection Device (SPD) is needed.

### 3.5.2 Other Considerations

Installing the radio near other electronic equipment can cause interference.

For sites with risk of ground fire, the recommended minimum installation height is 3 m.

### 3.5.3 Painting Disclaimer

Ericsson recommends to not paint the product as it can affect performance of the product.

Ericsson applies limitations to the warranty and service contract if the product is painted.

If the product is painted, the following commercial limitations apply:

- Failure modes directly related to overheating because of painting are not valid for repair within the scope of the warranty or standard service contract.
- Product failures related to paint contamination of components of the unit are not valid for repair within the scope of warranty or standard service contract.
- When a painted unit is repaired, it might be restored to the standard color before being returned to the market. It is not possible to guarantee that the same unit is sent back to the same place. This is also valid for units repaired under a service contract.
- For repairs within the warranty period or a standard service contract, the customer is charged the additional costs for replacing all painted parts of the unit or the complete unit.

If adaptations are required, contact Ericsson for information.

## 3.6 Space Requirements

### 3.6.1 Generic Requirements

Street Radio 4402 can be mounted as a single unit on top of a luminaire.



## 3.7 Acoustic Noise

The acoustic noise depends on the surrounding temperature, as listed below.

Table 5 Maximum Sound Power Level for Street Radio 4402 with Integrated Fan

| Temperature (°C) | Street Radio 4402 Sound Power Level $L_{WA}$ dB(A) |
|------------------|--|
| <+20             | 49   |
| +30              | 52   |
| +40              | 55   |
| +55              | 60   |

## 3.8 Environmental Characteristics

This section contains operating environment data for the radio.

### 3.8.1 Operating Environment

The following are the values for the normal operating environment of the radio:

Table 6 Operating Environment

| Description  | Value                          |
|--|--------------------------------|
| Temperature <sup>(1)</sup>                               | -40°C to +55°C                 |
| Solar radiation  | ≤1120 W/m <sup>2</sup>         |
| Relative humidity  | 5–100%                         |
| Absolute humidity  | 0.26–40 g/m <sup>3</sup>       |
| Maximum temperature change                               | 0.5°C/min                      |
| Maximum wind load at 42 m/s (pole-installed single unit) |                                |
| Street Radio 4402 B2/B25<br>Street Radio 4402 B66A       | 72 N (front/back), 88 N (side) |

<sup>(1)</sup> Depending on product variant, installation scenario, traffic load, and configuration, the product can, in the highest 15°C temperature range, temporarily reduce the output power by <2 dB. This depends on the durations of the high ambient temperature.

### 3.8.2 Heat Dissipation

The radio has a fan and is designed for outdoor installation.

Avoid indoor installation in a room without sufficient ventilation and cooling.

The maximum heat dissipation is calculated using the following formula:

$$\text{Max Heat Dissipation} = \text{Max Power Consumption} - \text{Configured Output Power}$$

Heat dissipation can be calculated for different traffic loads using values from Power Consumption Data. For more information, see Power Consumption Calculations.

### 3.8.3 Vibration

The radio operates reliably during seismic activity as specified by test method GR-3178.

Maximum level of Required Response Spectrum (RRS) 50 m/s<sup>2</sup> within 2–5 Hz for DR=2%

|                     |           |
|---------------------|-----------|
| Frequency range     | 0.3–50 Hz |
| Time history signal | Verteq II |

The radio operates reliably during random vibration as specified by test method IEC 60068-2-64 Fh method 1.

|                                    |                                    |                                    |                                    |
|------------------------------------|------------------------------------|------------------------------------|------------------------------------|
| Random vibration, normal operation | +12 m <sup>2</sup> /s <sup>3</sup> | 0.3 m <sup>2</sup> /s <sup>3</sup> | -12 m <sup>2</sup> /s <sup>3</sup> |
| Frequency range                    | 5–10 Hz                            | 10–50 Hz                           | 50–150 Hz                          |

### 3.8.4 Materials

All Ericsson products fulfill the legal and market requirements regarding the following:

- Material declaration
- Materials' fire resistance, components, wires, and cables
- Recycling
- Restricted and banned material use

## 3.9 Power Characteristics

This section describes the power supply requirements, power consumption, and circuit breaker recommendations for the radio.

### 3.9.1 AC Power Characteristics

The power supply voltage for Radio 4402 is +36 V DC, provided by the Support unit.

Table 7 Street Radio 4402 AC Power Supply Requirements

| Conditions                                    | Values and Ranges |
|---|-------------------|
| Nominal voltage                               | 110–480 V AC      |
| Normal voltage range at radio input connector | 110–480 V AC      |
| Non-destructive range                         | 0–528 V AC        |

### Circuit Breaker Recommendations

The recommendations given in this section are based on peak power consumption and give no information on power consumption during normal operation.

Table 8 Radio Circuit Breaker Recommendations

| Unit (DC Powered)        | Output Power (W) | Minimum CB Rating (A) | Maximum Allowed CB Rating <sup>(1)</sup> (A) |
|--------------------------|------------------|-----------------------|--|
| Street Radio 4402 B2/B25 | 4 × 5            | 16                    | 16   |
| Street Radio 4402 B66A   | 4 × 5            | 16                    | 16   |

(1) The absolute maximum circuit breaker class according to radio design restrictions.

### 3.9.2 Power Consumption

For information on power consumption, see Power Consumption Calculations and Power Consumption Data.

## 3.10 System Characteristics

This section describes the system characteristics of the Radio System.

### 3.10.1 RF Electromagnetic Exposure

For general information about RF EMF exposure, see Radio Frequency Electromagnetic Fields.

The following tables list the compliance boundaries (exclusion zones), outside of which the RF EMF exposure from Street Radio 4402 is below the limits specified by the ICNIRP and the limits applicable in:

- USA (47 CFR 1.1310)
- Canada (Health Canada Safety Code 6)

Table 9 Compliance Distance for General Public (GP) and Occupational (O) Exposure Applicable in USA and Markets Employing the FCC RF Exposure Limits (Including 0.6 dB Power Tolerance)

| Product                  | Standard | Maximum Nominal Output Power from the Radio | IEC 62232 Installation Class | Compliance Distance <sup>(1)</sup> (m) |     |
|--------------------------|----------|---|------------------------------|--|-----|
|                          |          |   |                              | GP                                     | O   |
| Street Radio 4402 B2/B25 | LTE / NR | 4 × 5 W                                     | E+                           | 1.4                                    | 0.7 |
| Street Radio 4402 B66A   | LTE / NR | 4 × 5 W                                     | E+                           | 1.4                                    | 0.7 |

(1) The compliance distances are determined for maximum nominal output power with power tolerance included.

Table 10 Compliance Distance for General Public (GP) and Occupational (O) Exposure Applicable in Canada (Including 0.6 dB Power Tolerance)

| Product                  | Standard | Maximum Nominal Output Power from the Radio | IEC 62232 Installation Class | Compliance Distance <sup>(2)</sup> (m) |     |
|--------------------------|----------|---|------------------------------|--|-----|
|                          |          |   |                              | GP                                     | O   |
| Street Radio 4402 B2/B25 | LTE / NR | 4 × 5 W                                     | E+                           | 2.1                                    | 0.9 |
| Street Radio 4402 B66A   | LTE / NR | 4 × 5 W                                     | E+                           | 2.0                                    | 0.9 |

(2) The compliance distances are determined for maximum nominal output power with power tolerance included.

### 3.10.2 Software

For information on software dependencies, see Supported Radio Capabilities.

### 3.10.3 Radio Configurations

For information about available radio configurations, see Radio Node Configurations.

# 4 Hardware Architecture

For a description of the supported radio configurations, see Radio Node Configurations.

**Note:** The Radio 4402 and Support 6523 units are separately replaceable when faulty.

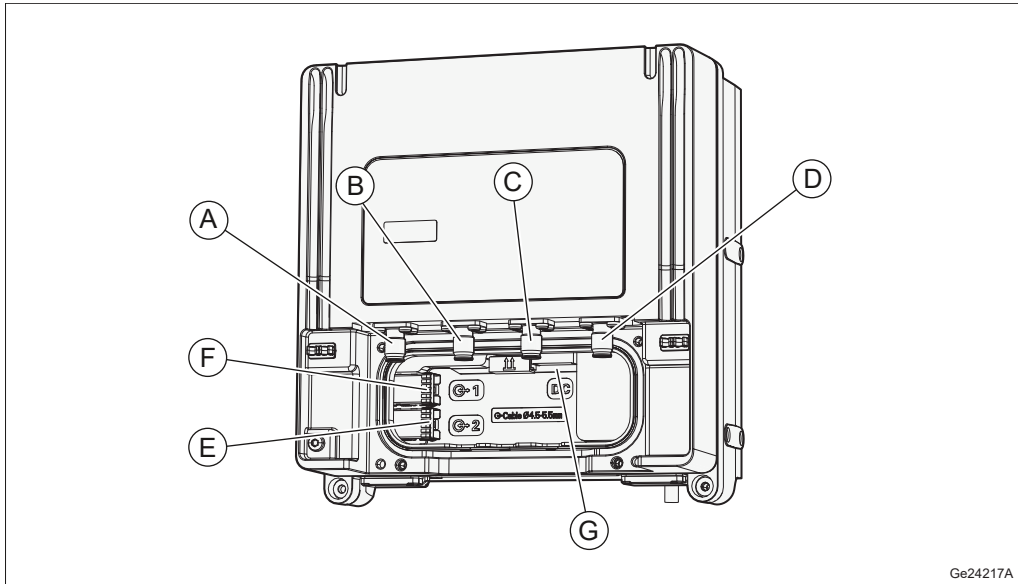

Ge24217A

Figure 4 Radio 4402

Table 11 Key to Radio Components

| Position | Component         |
|----------|-------------------|
| A–D      | Antenna ports A–D |
| E        | Optical cable 2   |
| F        | Optical cable 1   |
| G        | DC power supply   |

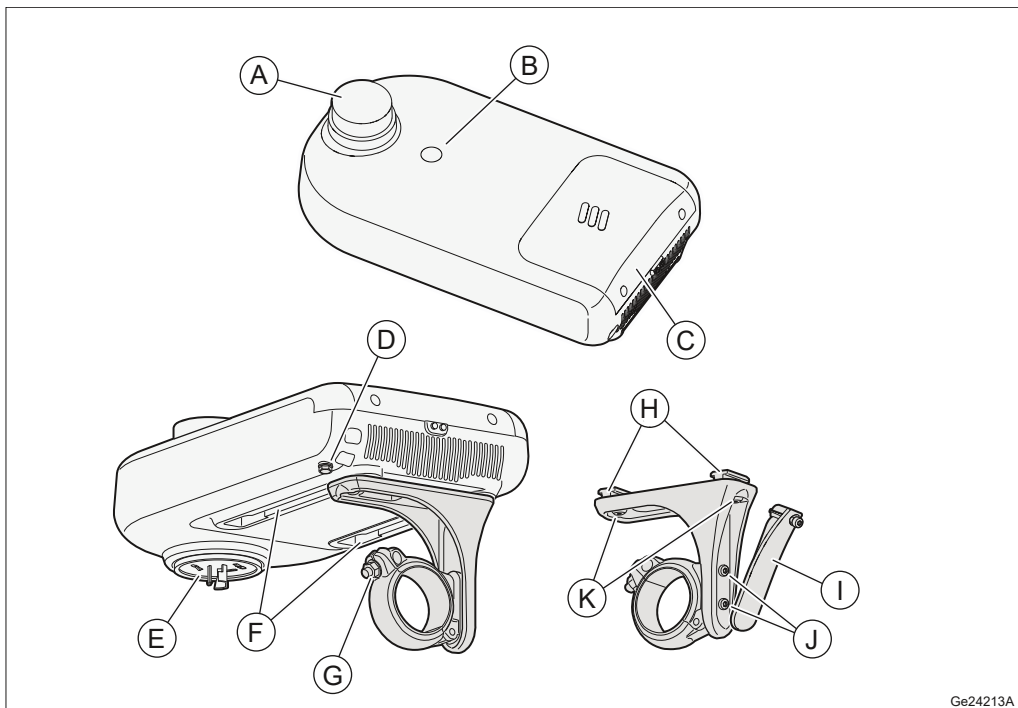

Ge24213A

Figure 5 Support 6523

Table 12 Key to Support Components

| Position | Component                    |
|----------|------------------------------|
| A        | Top NEMA cap                 |
| B        | ALS sensor                   |
| C        | Utility access cover         |
| D        | Grounding screw              |
| E        | Bottom NEMA plug             |
| F        | Mounting rails               |
| G        | Swivel locking nut           |
| H        | Shuttles                     |
| I        | Clamp adjustment cover       |
| J        | Vertical adjustment screws   |
| K        | Horizontal adjustment screws |

## 4.1 Support 6523

Support 6523 provides Radio 4402 with integrated mechanical attachment, AC power conversion, and cooling. It consists of four integrated antennas, a utility control board, a mounting bracket, a fan unit, and a PSU.

### 4.1.1 Mounting Bracket

The mounting bracket provides an integrated mechanical attachment for mounting the support on top of a luminaire pole with 2 3/8" (60 mm) diameter. Poles with a smaller diameter require a suitable engineering design that fulfills the local specifications.

### 4.1.2 Fan Unit

The fan unit is integrated in Support 6523 and operates autonomously against ambient temperature to cool Radio 4402.

### 4.1.3 PSU

The PSU is integrated in Support 6523 and provides DC power to Radio 4402 and the fan unit.

## 4.2 Radio 4402

Radio 4402 handles the radio communication in the unit and consists of a thermal radiator, TRX, and filter unit.

The antenna supervision can detect the following disconnected antennas:

- Integrated Omnidirectional Antennas

Use the AILG feature to ensure sufficient transmitted power.

### 4.2.1 Thermal Radiator

The thermal radiator provides cooling to the radio.

### 4.2.2 TRX

The Transmitter and Receiver (TRX) provides the following:

- Analog/Digital (A/D), Digital/Analog (D/A) conversion
- Channel filtering
- Delay and gain adjustment
- RF modulation and demodulation
- Optical cable interface termination
- Control and surveillance

### 4.2.3 Filter Unit

The Filter Unit consists of band-pass filters.

## 4.3 Antenna

The antennas are integrated in the Support 6523 unit.

# 5 Connection Interfaces

This section contains information about the radio connection interfaces.

## 5.1 Radio 4402

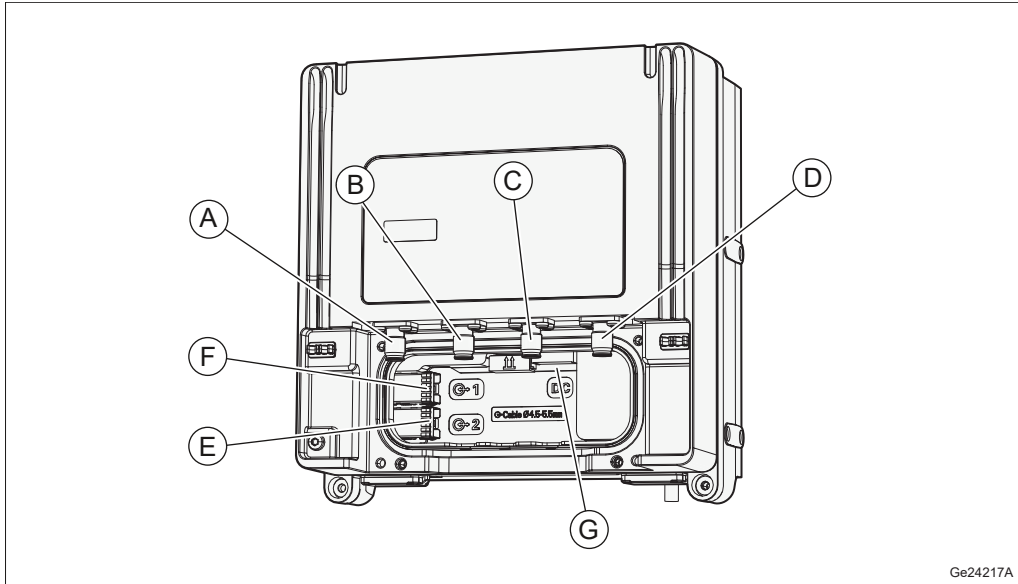

Figure 6 Radio 4402 Connection Interfaces

Table 13 Connection Interfaces

| Position | Description   | Marking | Connector Types | Cable Illustration |
|----------|---|---------|-----------------|--------------------|
| A        | Antenna A   |         | NEX10           |                    |
| B        | Antenna B   |         |                 |                    |
| C        | Antenna C   |         |                 |                    |
| D        | Antenna D   |         |                 |                    |
| E        | Optical cable 2   |         | LC (on SFP+)    |                    |
| F        | Optical cable 1<br><b>Note:</b> It must be used first in default configuration. |         |                 |                    |
| G        | DC power supply and internal communication                                      | DC      | -               | -                  |





### 5.1.1 Antenna Interface

The antenna interfaces provide connections for the radio to the antennas. RF cables connect the radio to the antennas.



Table 14 Radio Antenna Connection Interface Characteristics

| Connector Type | RF Cable Type                      |
|----------------|------------------------------------|
| NEX10 female   | 50 Ω 1/2-inch coaxial, 4.3-10 male |

Table 15 Radio Antenna Cable Connectors

| Radio Connectors  | Antenna Connectors |
|---|--------------------|
|  A (Antenna A) | TX/RX              |
|  B (Antenna B) | TX/RX              |
|  C (Antenna C) | TX/RX              |
|  D (Antenna D) | TX/RX              |

### 5.1.2 Interface for Optical Cable to Radio 4402 Unit

The  1 and  2 interfaces provide connections to optical cables (with outer diameter 4.5–5.5 mm, and comply with standard G657A2) for traffic and timing signals between the radio and the main unit. An SFP+ is used to connect the optical cable to the radio.

**Note:** The radio uses SFP modules for optical transmission and optical radio interfaces on Data 1 and Data 2.

Only SFP+ modules approved and supplied by Ericsson must be used. These modules fulfill the following:

- Compliance with Class 1 laser product safety requirements defined in standard IEC 60825-1
- Certification according to general safety requirements defined in standard IEC 60950-1
- Functional and performance verified to comply with Radio System specifications

Recommended SFP+ modules are obtained from the product packages for the Radio System and the Main Remote Installation products. For more information about SFP+ modules, see Spare Parts Catalog and Site Installation Products Overview.

### 5.1.3 DC Power Interface

The radio DC power connector provides Radio 4402 with +36 V DC and internal communication from the PSU.



## 6 Standards and Regulations

This section presents a brief overview of standards, regulatory product approval, and declaration of conformity for the radio.

### 6.1 Regulatory Approval

The Radio System complies with the following market requirements:

- North American market requirements
- Products containing radio equipment outside North America and in countries not recognizing the CE-mark can be labeled according to national requirements or standards

#### 6.1.1 Environmental Standards Compliance

The product complies with the following environmental standard:

##### Europe

- Restriction of Hazardous Substances in Electrical and Electronic Equipment (RoHS) Directive (2011/65/EU)

#### 6.1.2 Safety Standards Compliance

In accordance with market requirements, the Radio System complies with the following product safety standards and directives:

##### International

- IEC 62368-1

##### North America

- FCC CFR 47 Part 1.1310
- FCC CFR 47 Part 2.1091
- Health Canada Safety Code 6
- IC RSS-102
- UL 62368-1
- CSA-C22.2 No. 62368-1

##### 6.1.2.1 Outdoor-Specific Requirements

The Radio System complies with the following outdoor-specific requirements:

##### North America

- CSA-C22.2 No. 60950-22
- UL 50E
- UL 60950-22

### 6.1.3 EMC Standards Compliance

The Radio System complies with the following Electromagnetic Compatibility (EMC) standards:

#### North America

- IC ICES-003 B
- FCC CFR 47 Part 15 B

#### FCC Compliance Statement

This device complies with Part 15 of the FCC CFR 47 rules. Operation is subject to the following two conditions:

1. This device may not cause harmful interference.
2. This device must accept any interference received, including interference that may cause undesired operation.

### 6.1.4 Radio Standards Compliance

The Radio System complies with the following radio standards:

#### North America

- FCC CFR 47 Part 24 and 27 (USA frequency dependent)
- FCC CFR 47 Part 2 (USA)
- IC RSS-133, 139, and 199 (Canada frequency dependent)
- IC RSS-Gen (Canada)

**Note:** According to Innovation, Science and Economic Development Canada (Industry Canada):

For Canada, Radio 4402 B66 is authorized to operate in the B66A spectrum block DL: 2110–2180 MHz, UL: 1710–1780 MHz. For operation in the Band 66 (AWS-4) upper 20 MHz (DL: 2180–2200 MHz), operation is permitted by Industry Canada under a specific Industry Canada/Telco Licensing Agreement: P9-AWS-4 (Ancillary Terrestrial Component) Subordinate Spectrum Licenses.

<https://www.ic.gc.ca/eic/site/smt-gst.nsf/eng/sf11536.html>

### 6.1.5 Marking

To show compliance with legal requirements, the product is marked with the following labels:

#### North America

- usETL/cETL
- FCC CFR 47 Part 15 Statement
- IC ICES-003 Statement
- FCC ID
- IC ID

## 6.2 Other Standards and Regulations

The standards and regulations in this section are not regulatory approved.

## 6.2.1 Spare Parts

The product adheres to the Ericsson Serviceability and Spare Part Strategy.

## 6.2.2 Surface Quality

The surface quality of the radio is in accordance with Ericsson standard class A3.

Legal | © Ericsson AB 2022

|            |  |
|------------|--|
| Copyright  | © Ericsson AB 2022. All rights reserved. No part of this document may be reproduced in any form without the written permission of the copyright owner.   |
| Disclaimer | The contents of this document are subject to revision without notice due to continued progress in methodology, design and manufacturing. Ericsson shall have no liability for any error or damage of any kind resulting from the use of this document. |
| Trademarks | All trademarks mentioned herein are the property of their respective owners. These are shown in the document Trademark Information.  |