

Quick Install Guide



ubigrid™
DTM+

ubicquia®

ubigrid™ DTM+ Quick Install Guide

Contents

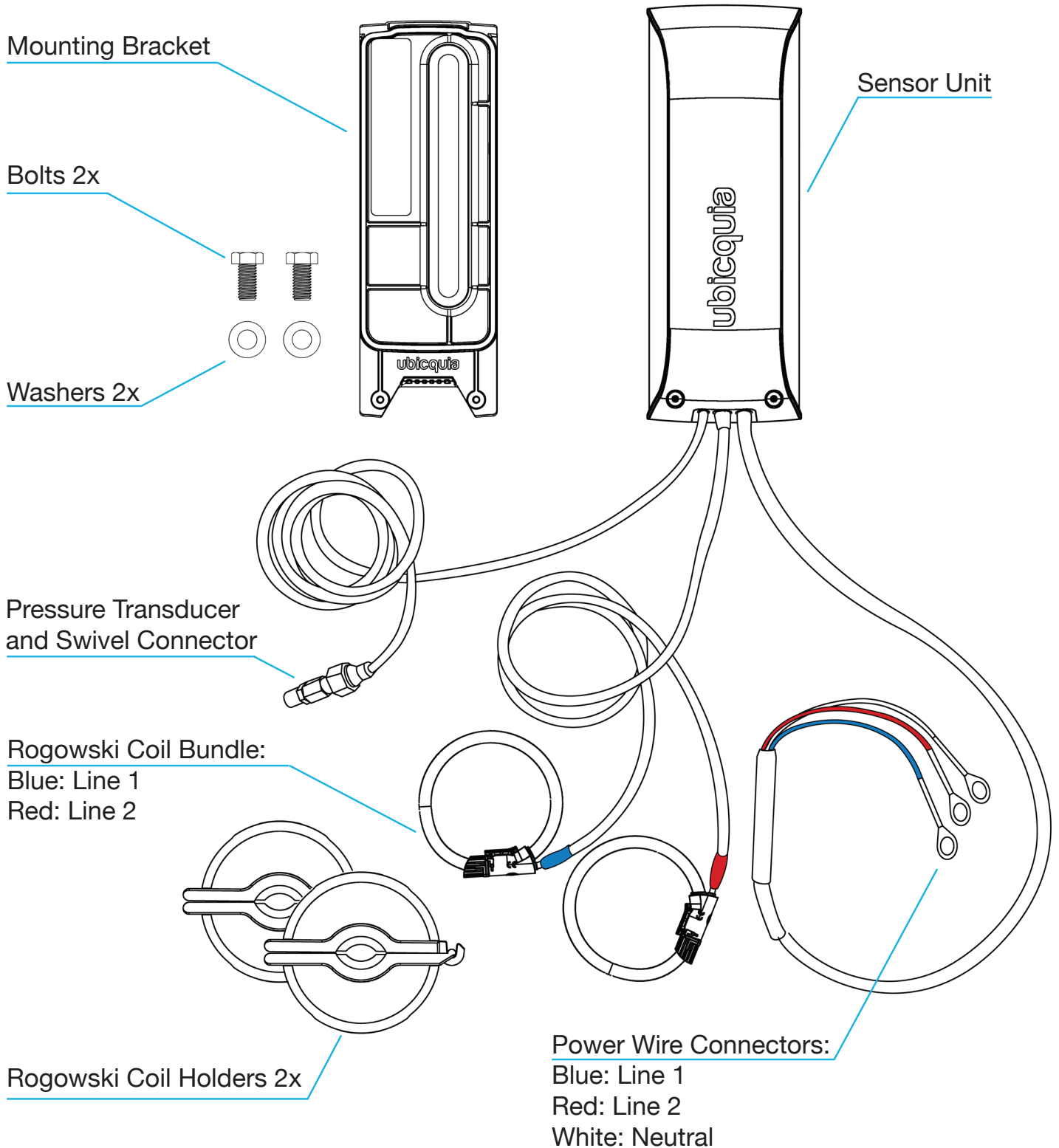

*OBS: Installation guide for de-energized units

ubigrid™ DTM+ Quick Install Guide

1. Installing the Bracket

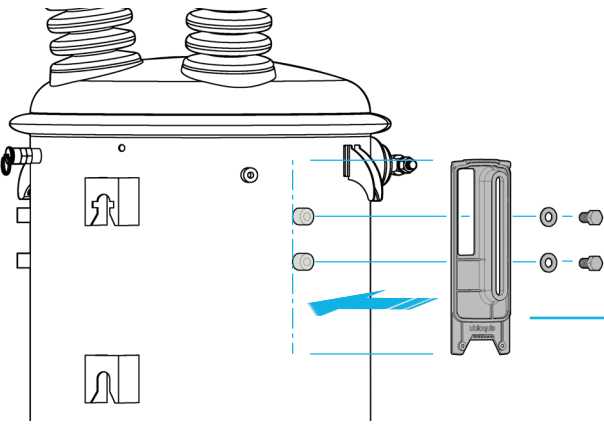

1a

Mount bracket to the open arrester provisions. (Can be either side).

1b

First install the bracket, and then a bolt and washer in each arrester provision.

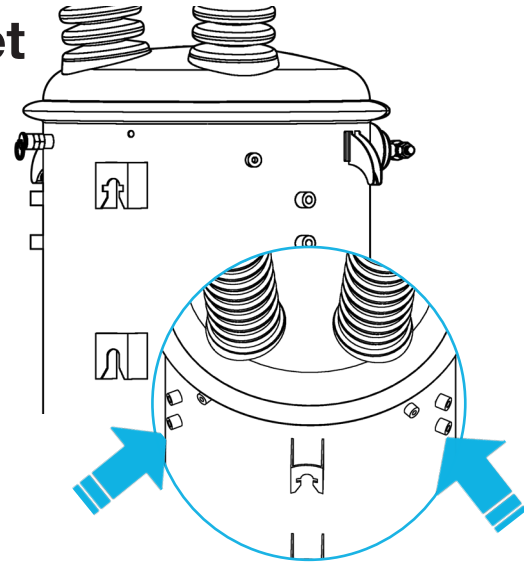

1c

Adjust mounting bracket up or down so the top is level with the pressure release valve. Tighten screws.

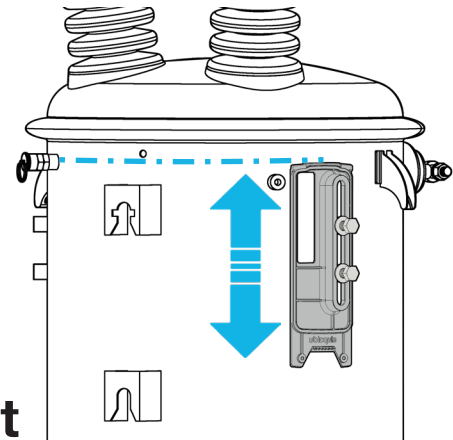
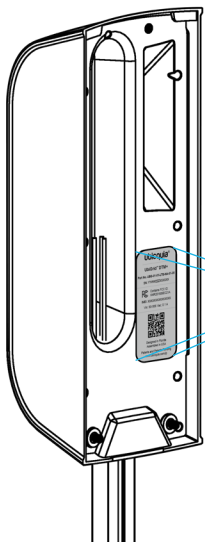

2. Scanning the Sensor Unit

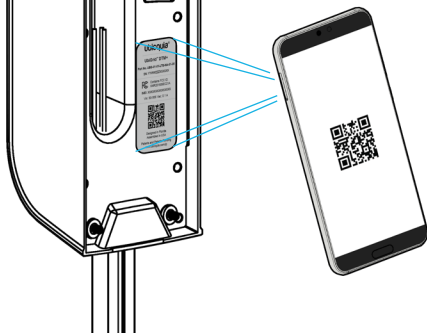

2a

Turn sensor unit over to reveal and scan the QR code. This is unique to each device confirming installation.

2b

Locate barcode on transformer and scan as well.

2c

The two units are now paired to one another.

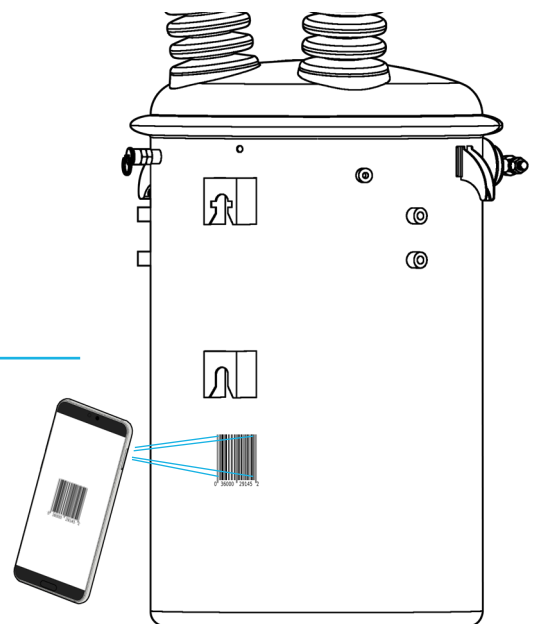
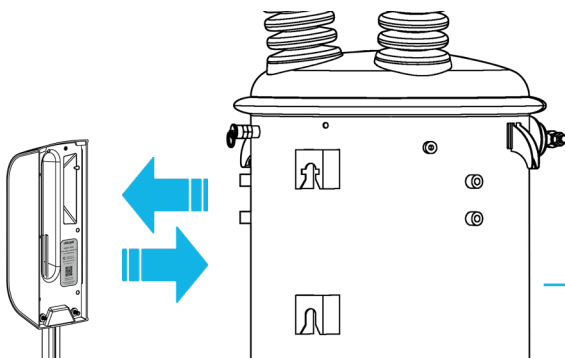

ubigrid™ DTM+ Quick Install Guide

3. Installing the Sensor Unit

3a

Hook in the top of the sensor unit to the top of the mounting bracket.

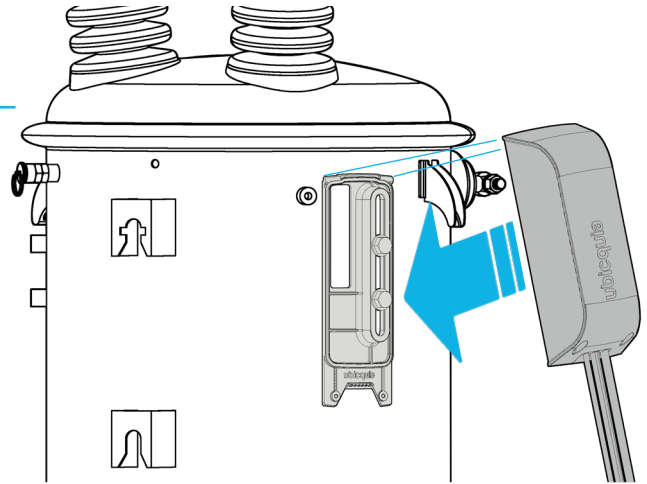

3b

Rotate the sensor downward until securely in place on the bracket.

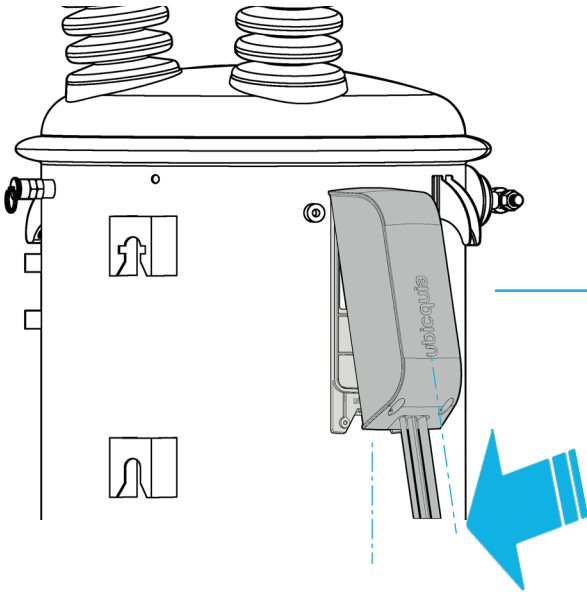

3c

Tighten the two mounting screws on the bottom of the sensor unit using a #2 Phillips screwdriver.

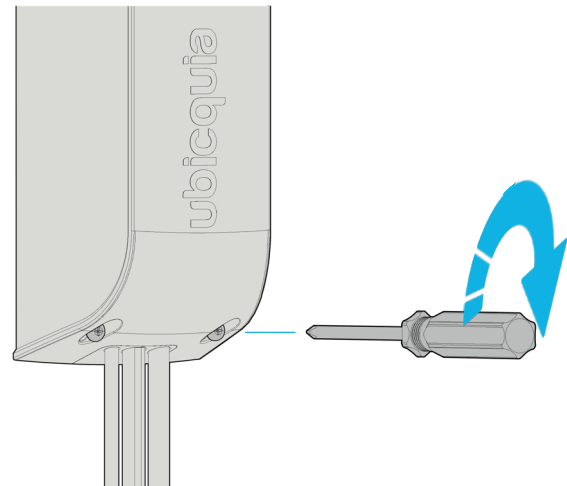

3d

The sensor unit is now secured in place.

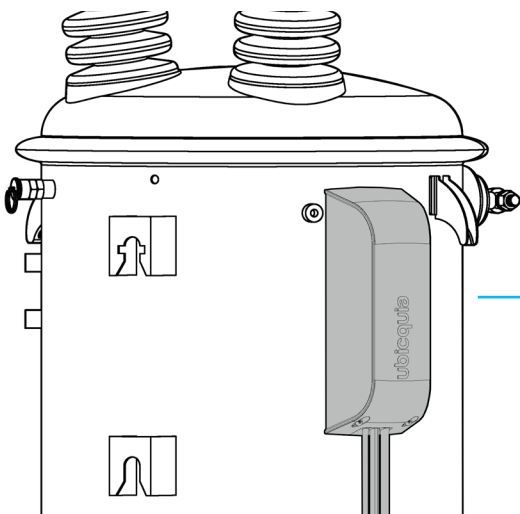

*FULL SENSOR ASSEMBLY

ubigrid™ DTM+ Quick Install Guide

4. Installing the Pressure Transducer

4a

Locate and remove the pressure release valve, as in the picture. Set aside.

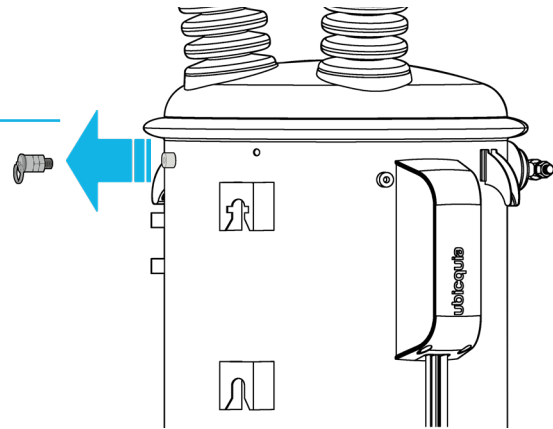
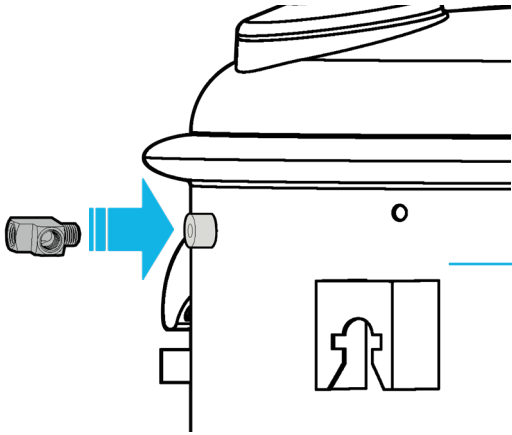

4b

Install the T Junction (provided) into the pressure release valve opening.

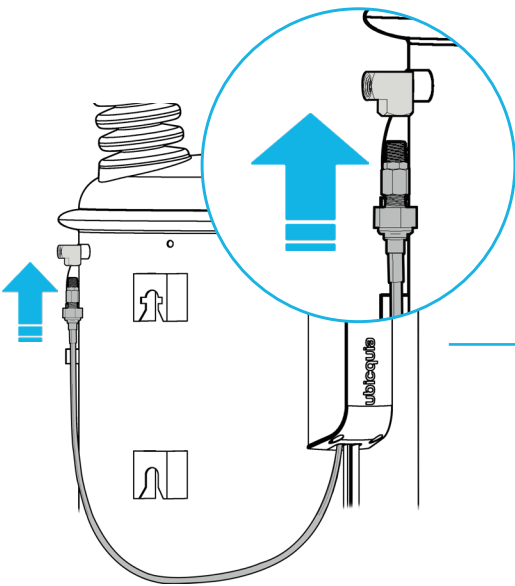

4c

The T Junction can be installed downward or horizontally if there is an obstruction. Tighten until properly secured in place.

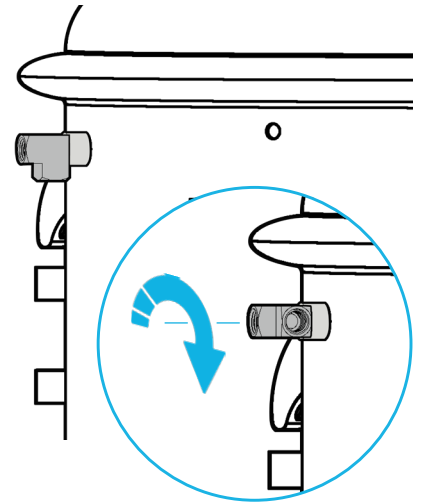

4d

Screw the swivel nut into the bottom or side opening on the T Junction until properly secured in place.

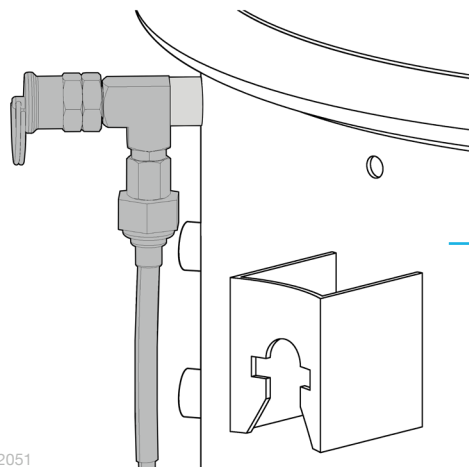

4e

Reinstall pressure release valve in the open end of the T Junction.

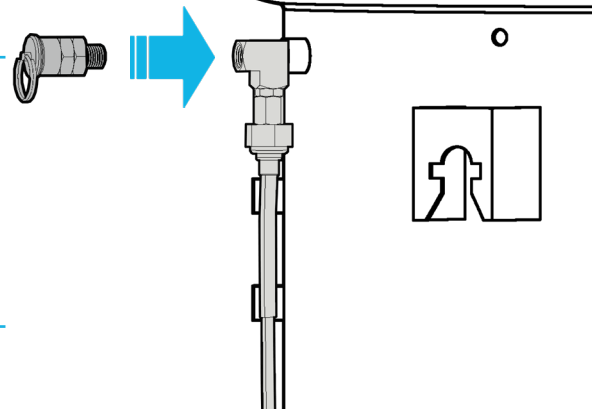

4f

Ensure pressure transducer and pressure release valve are installed correctly. Refer to image for proper assembly order.

ubigrid™ DTM+ Quick Install Guide

5. Installing the Wire Connectors

5a

Showing all three power wire connectors: blue (line 1), white (neutral) and red (line 2).
*OBS: During install, wires can freely touch surfaces.

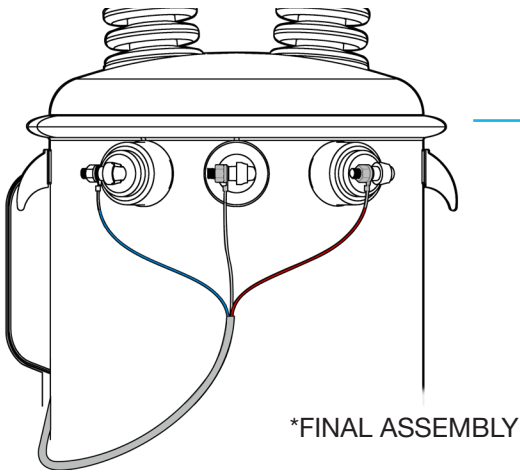

5b

Remove pre-assembled washer and nut from bushing eye bolt.

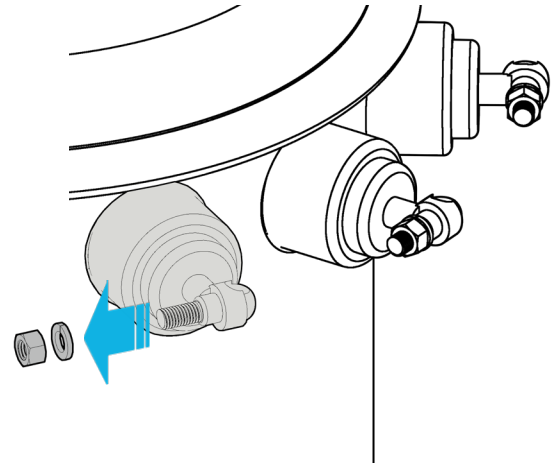

5c

Slide the power eyelet onto bushing eye bolt followed by a washer, and a nut.

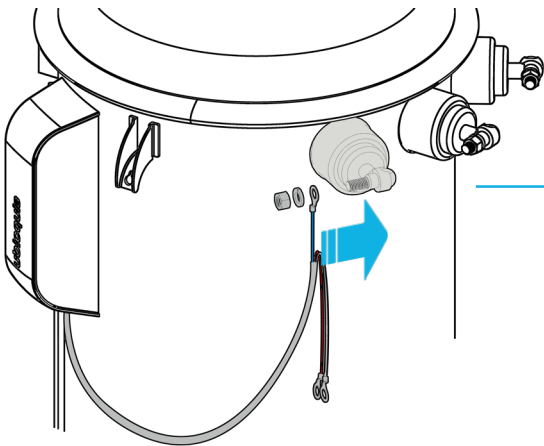

5d

Screw the nut until the components are properly tightened on the eye bolt.

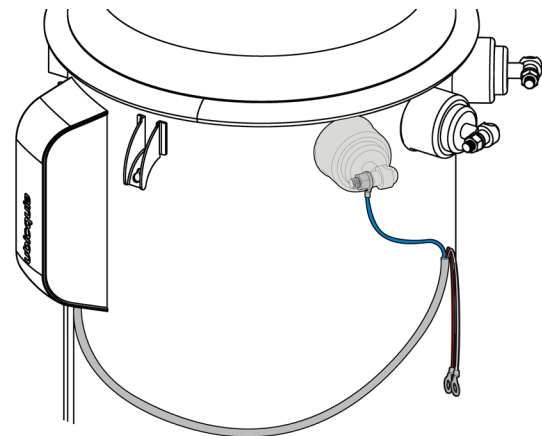

5e

Repeat step 5a-5d for the remaining two power wires.

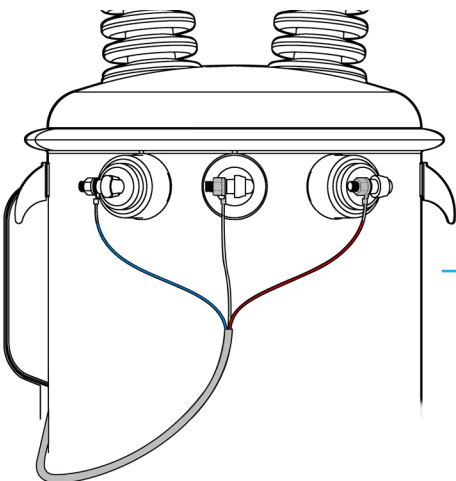

ubigrid™ DTM+ Quick Install Guide

6. Installing the Rogowski Coils

6a

The blue (line 1) and red (line 2) power wires must have the matching Rogowski coils installed on the bushings.

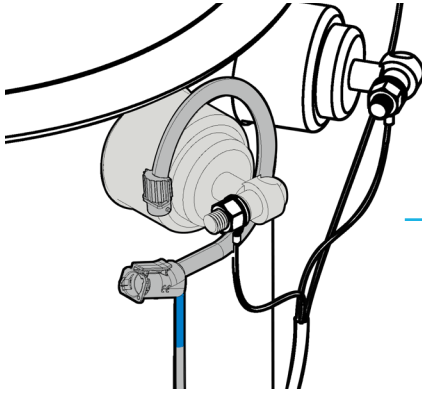
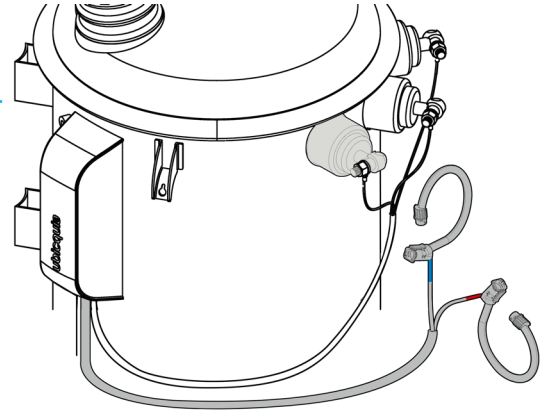

6b

Wrap the Rogowski coil around the bushing eye bolt, behind the wire assembly.

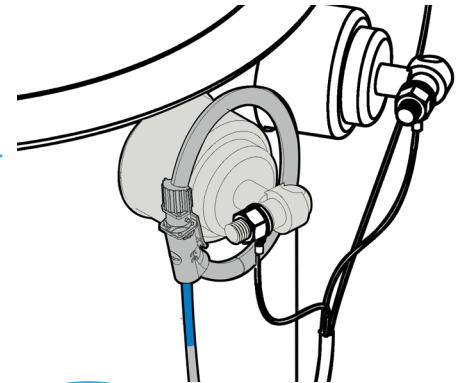

6c

Connect the Rogowski cable ends together by inserting and then twisting slightly until locked.

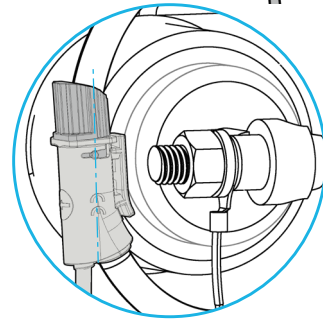
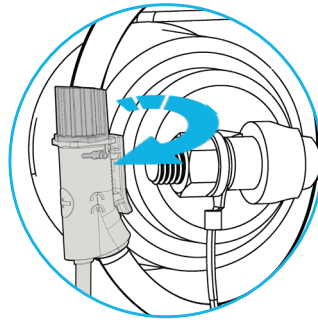
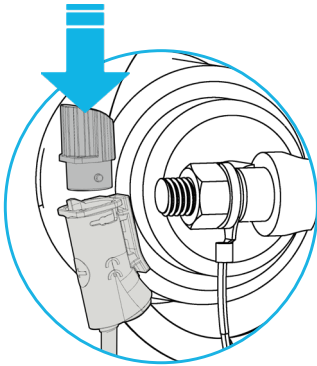

6d

A Rogowski holder is provided to secure the connected coil in place.

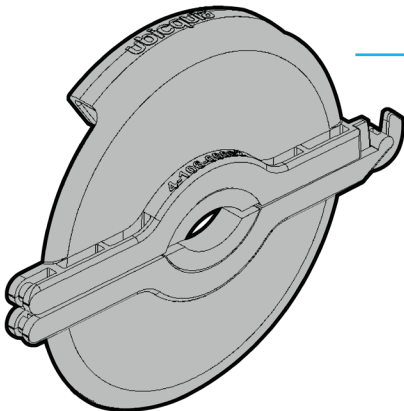

6e

Open the holder so that the top and bottom extend beyond the connected Rogowski coil.

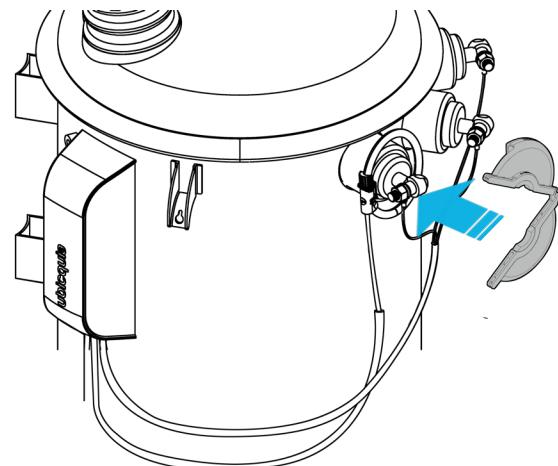

ubigrid™ DTM+ Quick Install Guide

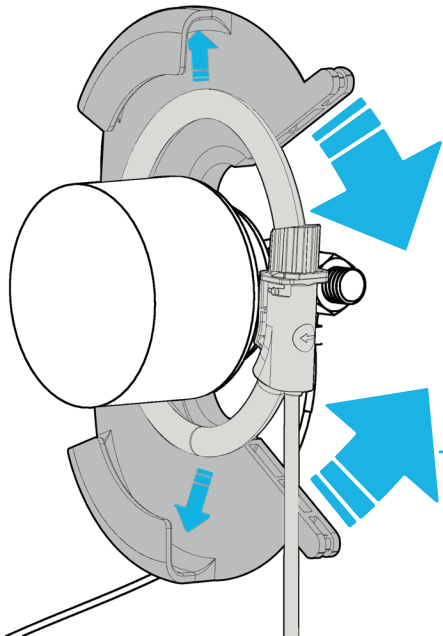

*SHOWING BACK FACE OF COIL HOLDER

6f

Slide the opened Rogowski holder over the Rogowski coil, ensuring the holder sits behind the bushing eye bolt and wire assembly.

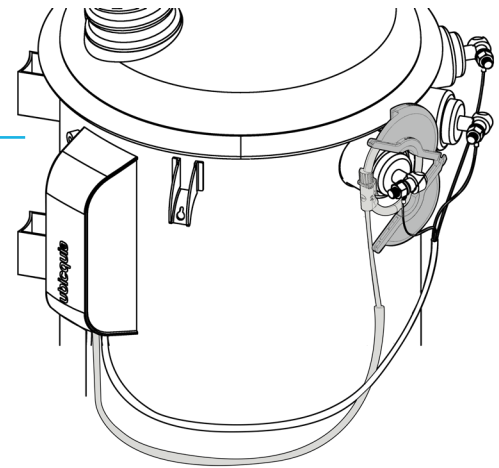

6g

Nest the coil within the top and bottom pockets of the Rogowski holder.

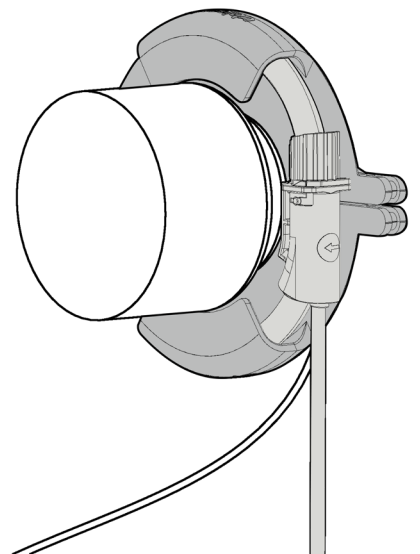

*SHOWING BACK FACE OF COIL HOLDER

6h

The housing should close snugly around the bushing with the wires hanging freely.

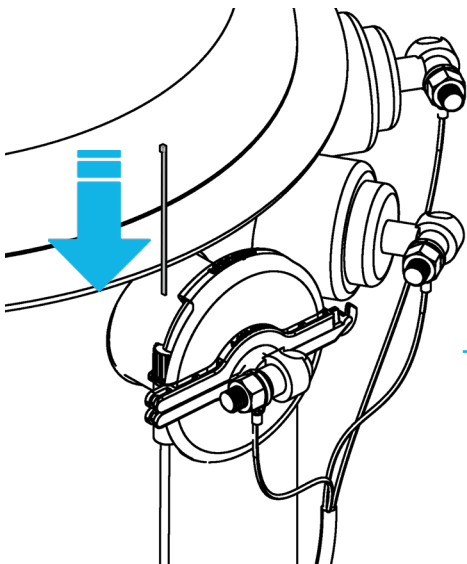

6i

Fasten the holder closed with a single zip tie.

6j

With the zip tie tightened, the Rogowski coil assembly is complete.

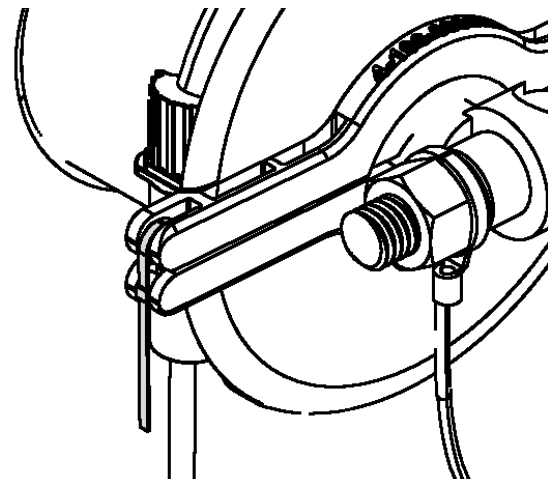

6k

Repeat steps 6b-6j with the remaining Rogowski coil and holder. Securing it around the matching power wire assembly.

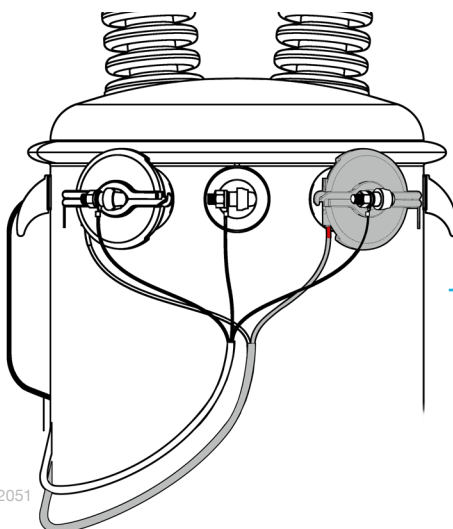

ubigrid™ DTM+ Quick Install Guide

7. Assembly Complete

7a

The UbiGrid DTM+ installation is complete. The transformer is ready to be installed onto a utility pole.

